

LEGEND

1201	HEAT EXCHANGER ASSEMBLY
1217	ISOLATION VALVE
1218	ISOLATION VALVE
1315	INST. CONTROL REGULATOR
1317	DISCHARGE ISOLATION VALVE
1326	BYPASS ISO VALVE
1330	PUMP CONTROL SOLENOID (NOT SHOWN)
1331	PUMP CONTROL SOLENOID (NOT SHOWN)
1338	FLAME ARRESTER
1339	CONDENSATE PUMP INLET CHECK VALVE
1401	INLET VESSEL
1405	CONDENSATE PUMP CHECK VALVE
1407	CONDENSATE PUMP
1408	CONDENSATE PUMP ISO VALVE
1409	CONDENSATE PUMP DRAIN VALVE
1411	CONDENSATE VESSEL
1412	LIQUID LEVEL SWITCH LOW
1414	MANUAL DUMP VALVE
1415	CONDENSATE CHECK VALVE
1416	LIQUID LEVEL SITE GAUGE
1518	LIQUID LEVEL SWITCH HIGH
1538	TEMPERATURE GAUGE INLET VESSEL
1540	TEMPERATURE GAUGE

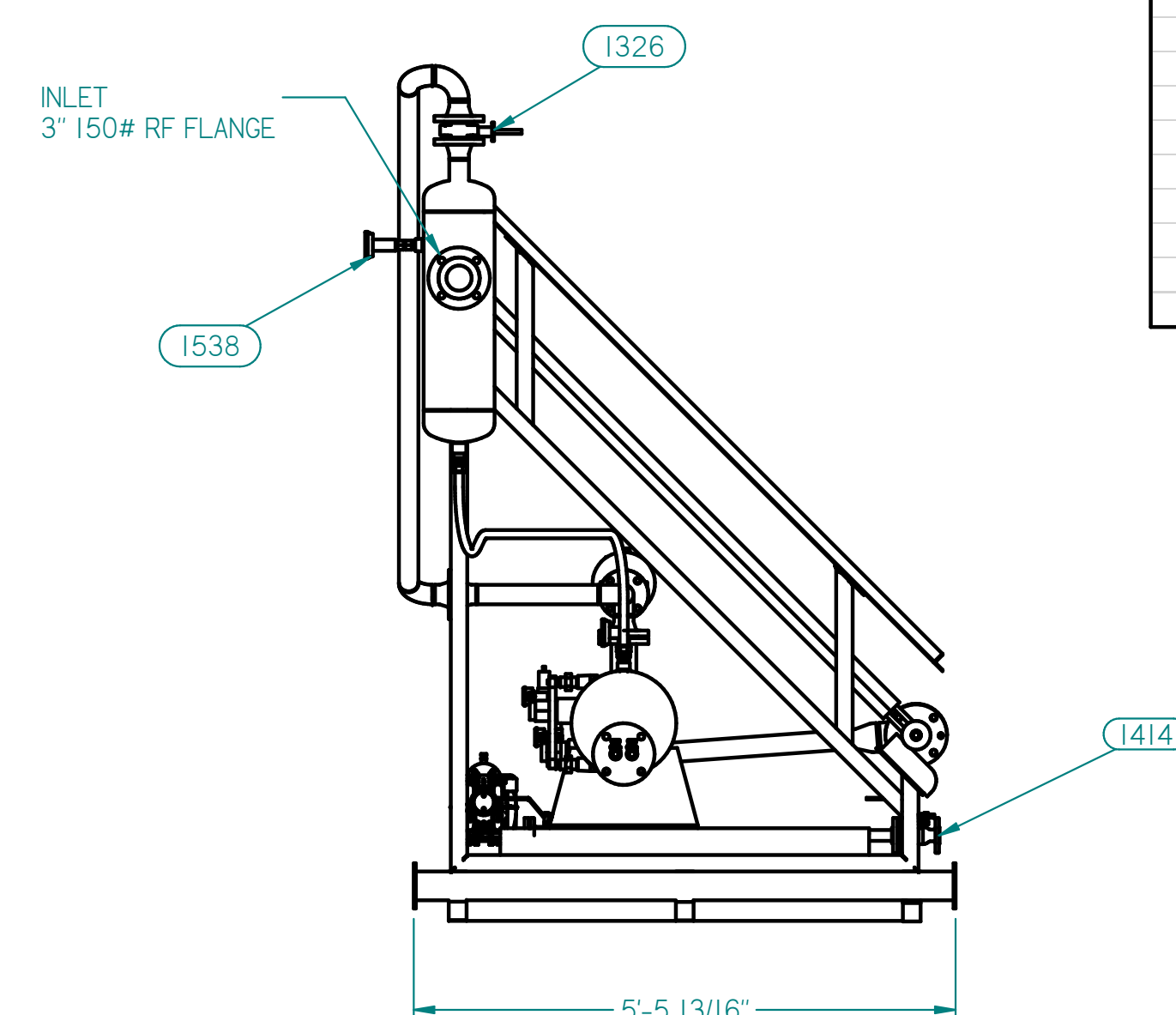
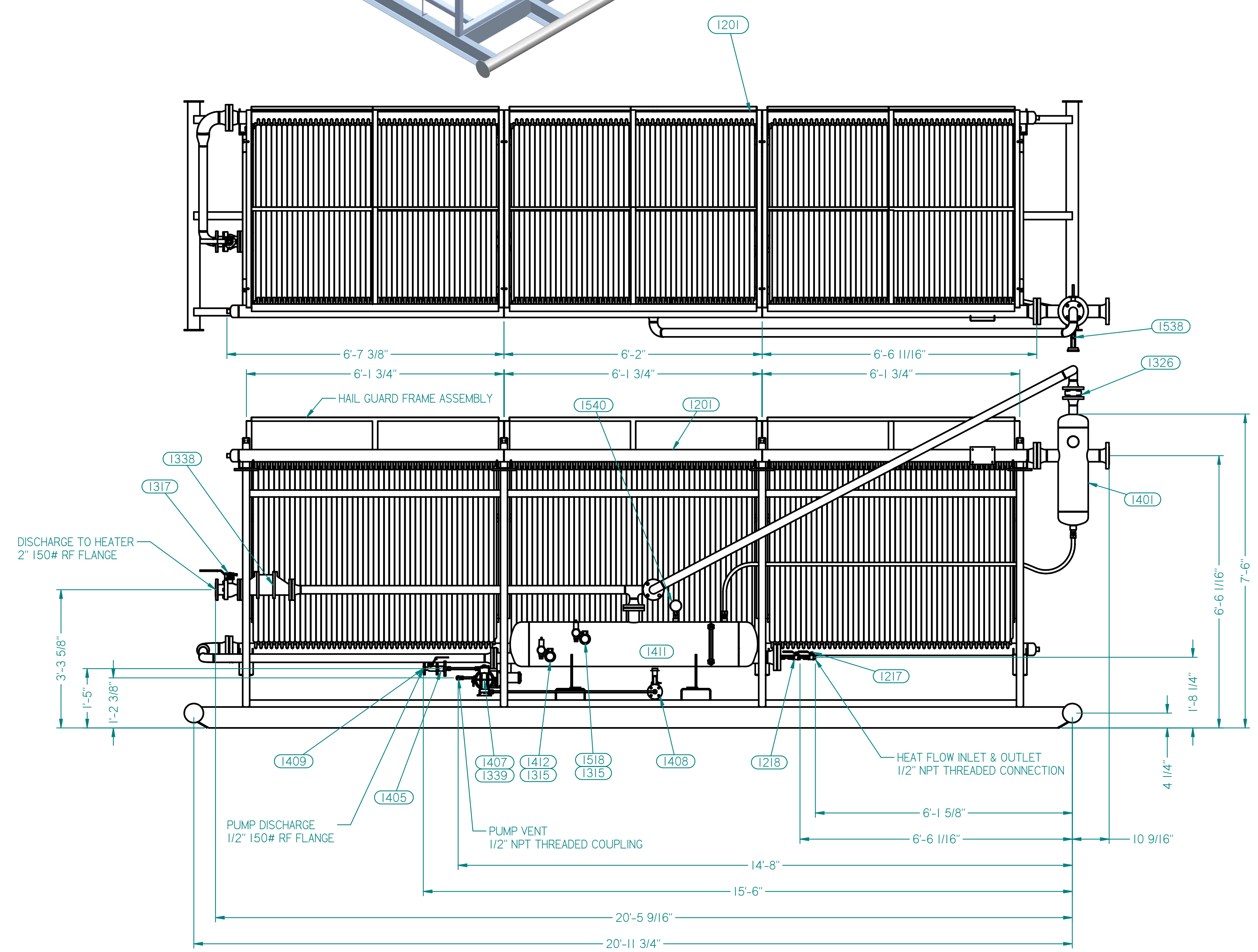

APPROXIMATE WEIGHT : 4,000 LBS

8-16-17	ADDED APPROX WEIGHT NOTE	DB
6/26/17	ADDED BYPASS LINE AND VALVE	DB
DATE	REVISION DESCRIPTION	BY

Tulsa, Ok. **TESCORP**
 Atlanta, Ga. P.O. Box 471453
 Tulsa, Oklahoma 74147

DATE: 5-31-17 SCALE: DRAWN BY: DB APPR'D: REVISION: 02

BTEX CONDENSER UNIT
 283 MBTUH CONVECTION AMBIENT AIR FLOW

CUSTOMER: ANADARKO DRAWING NUMBER: F-0517-0194GA